

**CD Stereo System**

# **SC-PM01**

**Operating Instructions**



# **Panasonic®**

Before connecting, operating or adjusting this product, please read these instructions completely. Please save this manual.

# Dear customer

Thank you for purchasing this product.  
For optimum performance and safety, please read these instructions carefully.

These operating instructions are applicable to the following system.

<b>System</b>	<b>SC-PM01</b>
Main unit	SA-PM01
Speakers	SB-PM01

The model number and serial number of this product can be found on either the back or the bottom of the unit. Please note them in the space provided below and keep for future reference.

	MODEL NUMBER	SERIAL NUMBER
Main unit	_____	_____
Speakers	_____	_____

**User memo:**

DATE OF PURCHASE \_\_\_\_\_  
 DEALER NAME \_\_\_\_\_  
 DEALER ADDRESS \_\_\_\_\_  
 \_\_\_\_\_  
 TELEPHONE NUMBER \_\_\_\_\_

**CAUTION!**  
 THIS PRODUCT UTILIZES A LASER.  
 USE OF CONTROLS OR ADJUSTMENTS OR PERFORMANCE OF PROCEDURES OTHER THAN THOSE SPECIFIED HEREIN MAY RESULT IN HAZARDOUS RADIATION EXPOSURE.  
 DO NOT OPEN COVERS AND DO NOT REPAIR YOURSELF. REFER SERVICING TO QUALIFIED PERSONNEL.

**CAUTION:**  
 TO PREVENT ELECTRIC SHOCK MATCH WIDE BLADE OF PLUG TO WIDE SLOT, FULLY INSERT.

Before use

# Supplied accessories



Please check and identify the supplied accessories.  
Use numbers indicated in brackets when asking for replacement parts.

*(Only for U.S.A.)*  
 To order accessories contact 1-800-332-5368 or web site (<http://www.panasonic.com>).

- AC power supply cord ..... 1 pc. (SJA172)

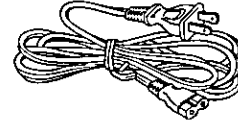

- FM indoor antenna ..... 1 pc. (RSA0006)



- AM loop antenna ..... 1 pc. (RSA0025)

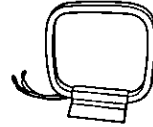

- Remote control transmitter ..... 1 pc. (EUR645401)



- Remote control batteries ..... 2 pc. (R6/LR6, AA, UM-3)



# Table of contents

## Before use

Precautions .....	4
Placement of speakers .....	5
Concerning the remote control .....	5
Connections .....	6
Basic connections (for supplied accessories) .....	6
Optional antenna connections .....	7
External unit connection .....	7
Front panel controls .....	8

## Preparations

Setting the time .....	9
Presetting radio broadcasts .....	10

## Radio operations

Listening to radio broadcasts .....	11
-------------------------------------	----

## CD operations

Listening to CDs .....	12
Normal play .....	12
Direct access play .....	13
Repeat play and random play .....	13
Program play .....	14

## Adjustments

Changing the sound quality, etc .....	15
To adjust the tone quality .....	15
Using the "live" effect (SOUND VIRTUALIZER) .....	15
To mute the volume .....	15
To dim out the display .....	15

## Timer operations

Using the timer .....	16
Using the play timer .....	16
Using the sleep timer .....	18

## Other functions

Using the timer fader function (TIMER FADER) .....	18
Using an external unit .....	19

## Reference

Concerning CDs .....	19
Troubleshooting guide .....	20
Maintenance .....	21
Technical specifications .....	22
Product service .....	23

THE FOLLOWING APPLIES ONLY IN THE U.S.A.:

### CAUTION:

This equipment has been tested and found to comply with the limits for a Class B digital device, pursuant to Part 15 of the FCC Rules.

These limits are designed to provide reasonable protection against harmful interference in a residential installation. This equipment generates, uses and can radiate radio frequency energy and, if not installed and used in accordance with the instructions, may cause harmful interference to radio communications. However, there is no guarantee that interference will not occur in a particular installation. If this equipment does cause harmful interference to radio or television reception, which can be determined by turning the equipment off and on, the user is encouraged to try to correct the interference by one of the following measures:

- Reorient or relocate the receiving antenna.
- Increase the separation between the equipment and receiver.
- Connect the equipment into an outlet on a circuit different from that to which the receiver is connected.
- Consult the dealer or an experienced radio/TV technician for help.

FCC Notice: This system complies with new Part 15, except for the radio receiver, which complies with old Part 15, Subpart C of the FCC Rules. Operation is subject to the following two conditions: (1) This device may not cause harmful interference, and (2) this device must accept any interference received, including interference that may cause undesirable operation. The radio receiver is not subject to above item (2).

Any unauthorized changes or modifications to this equipment would void the user's authority to operate this device.

### WARNING:

**TO REDUCE THE RISK OF FIRE, ELECTRIC SHOCK OR PRODUCT DAMAGE, DO NOT EXPOSE THIS APPLIANCE TO RAIN, SPLASHING, DRIPPING OR MOISTURE.**



**CAUTION**

**RISK OF ELECTRIC SHOCK  
DO NOT OPEN**



**CAUTION: TO REDUCE THE RISK OF ELECTRIC SHOCK, DO NOT REMOVE SCREWS. NO USER-SERVICEABLE PARTS INSIDE. REFER SERVICING TO QUALIFIED SERVICE PERSONNEL.**



The lightning flash with arrowhead symbol, within an equilateral triangle, is intended to alert the user to the presence of uninsulated "dangerous voltage" within the product's enclosure that may be of sufficient magnitude to constitute a risk of electric shock to persons.



The exclamation point within an equilateral triangle is intended to alert the user to the presence of important operating and maintenance (servicing) instructions in the literature accompanying the appliance.

Before use

# Precautions

Before using this unit please read these operating instructions carefully. Take special care to follow the warnings indicated on the unit itself as well as the safety suggestions listed below. Afterwards keep them handy for future reference.

Before use

## Safety

- Power Source**—The unit should be connected to power supply only of the type described in the operating instructions or as marked on the unit.
- Polarization**—If the unit is equipped with a polarized AC power plug (a plug having one blade wider than the other), that plug will fit into the AC outlet only one way. This is a safety feature. If you are unable to insert the plug fully into the outlet, try reversing the plug. If the plug should still fail to fit, contact your electrician to replace your obsolete outlet. Do not defeat the safety purpose of the polarized plug.
- Power Cord Protection**—AC power supply cords should be routed so that they are not likely to be walked on or pinched by items placed upon or against them. Never take hold of the plug or cord if your hand is wet, and always grasp the plug body when connecting or disconnecting it.
- Nonuse Periods**—When the unit is not used, turn the power off. When left unused for a long period of time, the unit should be unplugged from the household AC outlet.

## Installation

### Environment

- Outdoor Antenna Grounding**—If an outside antenna is connected to the receiver, be sure the antenna system is grounded so as to provide some protection against voltage surges and built-up static charges. Section 810 of the National Electrical Code, ANSI/NFPA No. 70-1990, provides information with respect to proper grounding of the mast and supporting structure, grounding of the lead-in wire to an antenna discharge unit, size of grounding conductors, location of antenna-discharge unit, connection to grounding electrodes, and requirements for the grounding electrode. See figure below.

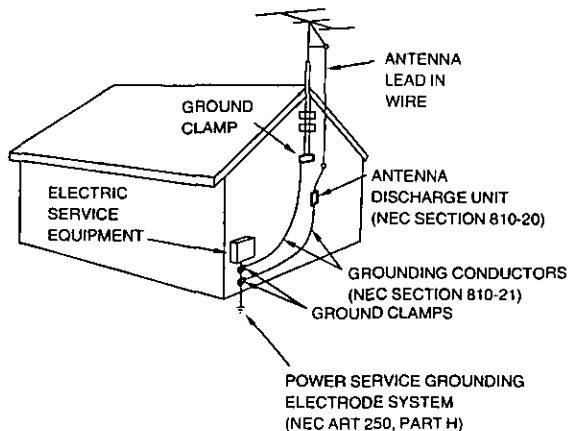

NEC—NATIONAL ELECTRICAL CODE

- Water and Moisture**—Do not use this unit near water—for example, near a bathtub, washbowl, swimming pool, or the like. Damp basements should also be avoided.

- Heat**—The unit should be situated away from heat sources such as radiators and the like. It also should not be placed in temperatures less than 5°C (41°F) or greater than 35°C (95°F).
- Condensation**—Moisture may form on the lens in the following conditions...
  - immediately after a heater has been turned on.
  - in a steamy or very humid room.
  - when the unit is suddenly moved from a cold environment to a warm one.
 If moisture forms inside this unit, it may not operate properly. To correct this problem, turn on the power and wait about one hour for the moisture to evaporate.

## Placement

- Ventilation**—The unit should be situated so that its location or position does not interfere with its proper ventilation. Allow 10 cm (4") clearance from the rear of the unit.
- Foreign Material**—Care should be taken so that objects do not fall into and liquids are not spilled into the unit. Do not subject this unit to excessive smoke, dust, mechanical vibration, or shock.
- Magnetism**—The unit should be situated away from equipment or devices that generate strong magnetic fields.
- Stacking**—Do not place heavy objects, other than system components, on top of the unit.
- Surface**—Place the unit on a flat, level surface.
- Carts and Stands**—The unit should be used only with a cart or stand that is recommended by the manufacturer. The unit and cart combination should be moved with care. Quick stops, excessive force, and uneven surfaces may cause the unit and cart combination to overturn.
- Wall or Ceiling Mounting**—The unit should not be mounted to a wall or ceiling, unless specified in this operating instructions.



## Maintenance

(See page 21 for details.)

Clean the cabinet, panel and controls with a soft cloth lightly moistened with mild detergent solution. Do not use any type of abrasive pad, scouring powder or solvent such as alcohol or benzine.

## Service

- Damage Requiring Service**—The unit should be serviced by qualified service personnel when:
  - The AC power supply cord or the plug has been damaged; or
  - Objects have fallen or liquid has been spilled into the unit; or
  - The unit has been exposed to rain; or
  - The unit does not appear to operate normally or exhibits a marked change in performance; or
  - The unit has been dropped, or the enclosure damaged.
- Servicing**—The user should not attempt to service the unit beyond that described in the operating instructions. All other servicing should be referred to an authorized service personnel.  
**For the address of an authorized servicenter:**  
*In the U.S.A. 1-800-211-7262 or web site (<http://www.panasonic.com>)*  
*In Canada 905-624-5505 or web site ([www.panasonic.ca/fdbckca.htm](http://www.panasonic.ca/fdbckca.htm))*

## Listening caution



Selecting fine audio equipment such as the unit you've just purchased is only the start of your musical enjoyment. Now it's time to consider how you can maximize the fun and excitement your equipment offers. This manufacturer and the Electronic Industries Association's Consumer Electronics Group want you to get the most out of your equipment by playing it at a safe level. One that lets the sound come through loud and clear without annoying blaring or distortion—and, most importantly, without affecting your sensitive hearing.

We recommend you to avoid prolonged exposure to excessive noise.

Sound can be deceiving. Over time your hearing "comfort level" adapts to higher volumes of sound. So what sounds "normal" can actually be loud and harmful to your hearing.

Guard against this by setting your equipment at a safe level BEFORE your hearing adapts.

To establish a safe level:

- Start your volume control at a low setting.
- Slowly increase the sound until you can hear it comfortably and clearly, and without distortion.

Once you have established a comfortable sound level:

- Set the dial and leave it there.

Taking a minute to do this now will help to prevent hearing damage or loss in the future. After all, we want you listening for a lifetime.

## Placement of speakers

Speakers are designed identically so that no left or right channel orientation is necessary.

These speakers have bass-reflex ports on the rear. For best bass effect, place them between 5 and 40 cm from a wall.

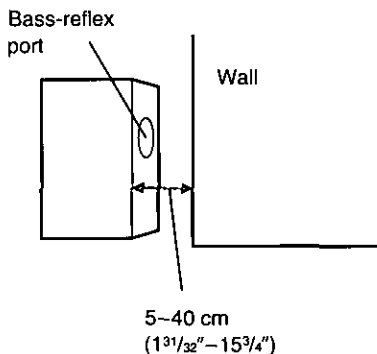

## Concerning the remote control

### Battery installation

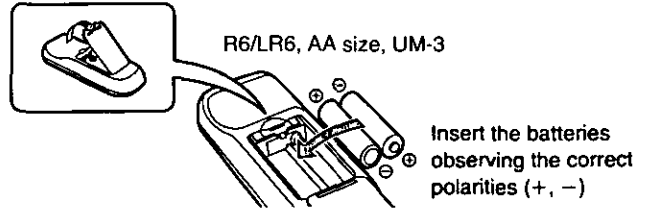

### Use of batteries

- Do not mix old and new batteries, or batteries of different types (manganese and alkaline, etc.).
- Never subject batteries to excessive heat or flame; do not attempt to disassemble them; and be sure they are not short-circuited.
- If the remote control is not to be used for a long period of time, remove the batteries and store them in a cool, dark place.
- Do not attempt to recharge alkaline or manganese batteries.
- Do not use rechargeable type batteries.

### Battery life

The battery life is about one year.

The batteries should be replaced if commands from the remote control transmitter do not operate the unit even when the transmitter is held close to the front panel.

### Correct method of use

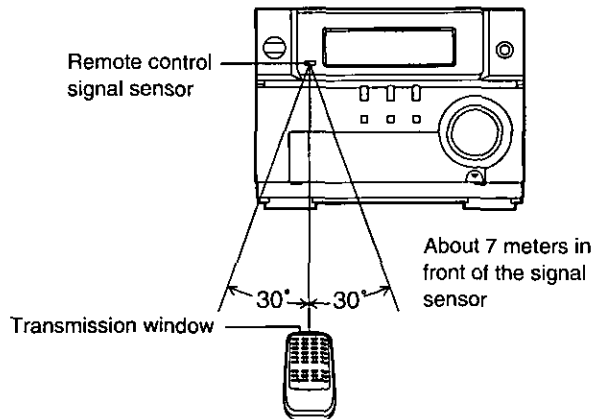

### Operation notes

- Do not place obstacles between the remote control signal sensor and remote control unit.
- Do not expose the remote control signal sensor to direct sunlight or to the bright light of an inverter fluorescent light.
- Take care to keep the remote control signal sensor and end of the remote control unit free from dust.
- If this system is installed in a rack with glass doors, the glass doors' thickness or color might make it necessary to use the remote control a shorter distance from the system.

### To prevent damage

- Do not place heavy items on top of the unit.
- Do not disassemble or reconstruct the unit.
- Do not spill water or other liquids.

## Connections

### Basic connections (for supplied accessories)

- Plug the AC power cord into a household AC outlet only after all other connections have been made.
- To prepare the AM loop antenna wire and speaker cords, twist the vinyl cover tip and pull off.
- For your listening pleasure, keep your speakers from touching the system.
- Speakers are designed identically so that no left or right channel orientation is necessary.

#### 1 Connect the FM indoor antenna.

Tape the antenna to a wall or column, in a position where radio signals are received with the least amount of interference.

#### Note

For best reception sound quality:

An FM outdoor antenna is recommended. (See page 7.)

#### 2 Connect the AM loop antenna.

After attaching the antenna, turn on the system and tune in a broadcast station. Put the antenna where reception is best and interference is minimal.

#### 3 Connect the right (R) and left (L) speaker cables.

#### Note

• To prevent damage to circuitry, never short-circuit positive (+) and negative (-) speaker wires.

• Be sure to connect only positive (red) wires to positive (+) terminals and negative (black) wires to negative (-) terminals.

#### Caution

Use the speakers only with the recommended system. Failure to do so may lead to damage to the amplifier and/or the speakers, and may result in the risk of fire. Consult a qualified service person if damage has occurred or if you experience a sudden change in performance.

#### 4 Connect the AC power cord.

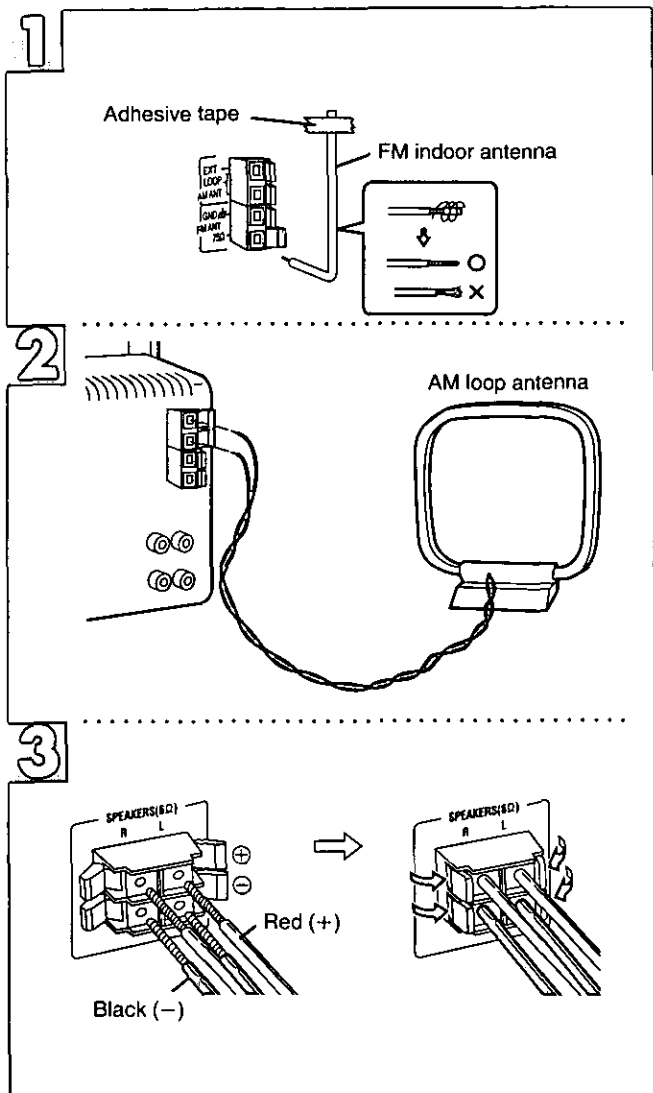
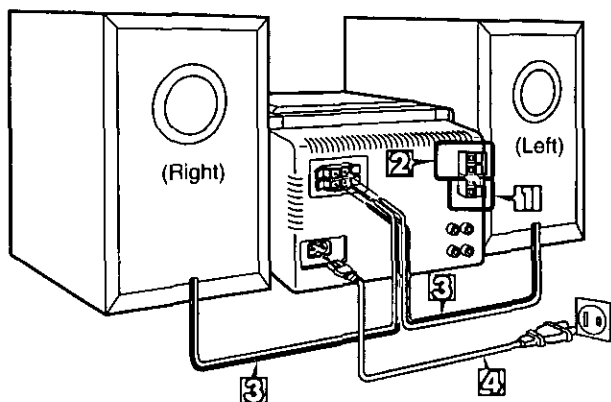

## Connections

### Optional antenna connections

You may need an outdoor antenna if you use this system in a mountainous region or inside a reinforced-concrete building, etc.

#### FM outdoor antenna

Disconnect the FM indoor antenna if an FM outdoor antenna is installed.

- ① Remove a piece of the outer vinyl insulator.
- ② Twist the shield braid.
- ③ Expose the core wire.

#### Note

An outdoor antenna should be installed by a qualified technician only.

#### AM outdoor antenna

Connect the outdoor antenna without removing the AM loop antenna. Run 5 to 12 m of vinyl-covered wire horizontally along a window or other convenient location.

#### Note

When the unit is not in use, disconnect the outdoor antenna to prevent possible damage that may be caused by lightning. Never use an outdoor antenna during an electrical storm.

### External unit connection

- For details, refer to the instruction manual of the units which are to be connected.
- When units other than these are to be connected, please consult with your audio dealer.

This example shows how to connect a cassette tape deck.

#### Note

If you connect an analog player to the "AUX/LINE IN" terminals, be sure it has a built-in phono equalizer.

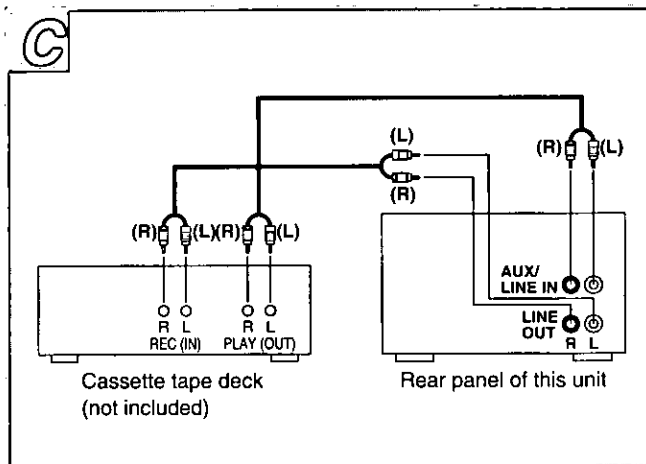
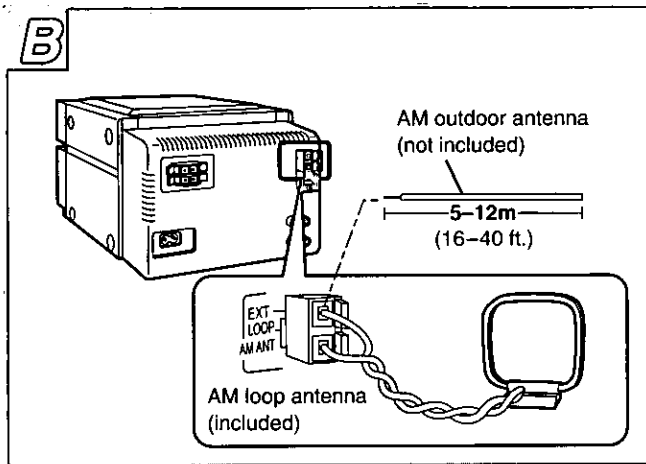
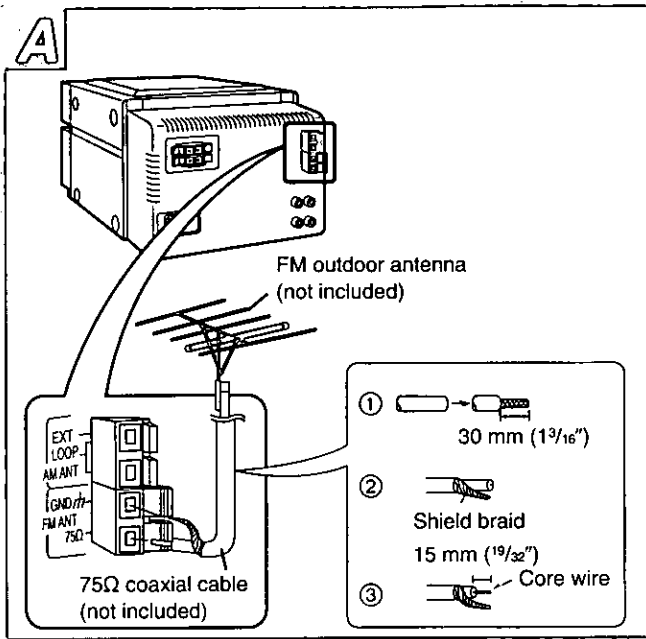

## Front panel controls

No.	Name	Ref. page
①	<b>Power switch (POWER)</b> .....	9
	Press to switch the unit from on to standby mode or vice versa. In standby mode, the unit is still consuming a small amount of power.	
②	<b>Remote control signal sensor (SENSOR)</b> .....	5
③	<b>Multi-function display panel (MULTI-FUNCTION DISPLAY)</b>	
④	<b>Tuner/band select button (TUNER/BAND)</b> .....	10, 11
⑤	<b>CD play/pause button (CD, ▷/  )</b> .....	12
⑥	<b>AUX button (AUX)</b> .....	19
⑦	<b>CD stop button (□)</b> .....	12
⑧	<b>Tuning/skip/search/time adjust buttons (-/◀◀/◀◀, +/▶▶/▶▶)</b> .....	9, 10, 11, 12
⑨	<b>Volume control (VOLUME)</b> .....	11, 12
⑩	<b>Sound virtualizer button (SOUND VIRTUALIZER)</b> .....	15
⑪	<b>Memory button (MEMORY)</b> .....	10
⑫	<b>Tuning mode select button (TUNE MODE)</b> .....	10, 11
⑬	<b>Clock/timer button (CLOCK/TIMER)</b> .....	9, 16
⑭	<b>Play timer button (⌚ PLAY)</b> .....	16
⑮	<b>Timer fader button (TIMER FADER)</b> .....	18
⑯	<b>Front cover</b>	
⑰	<b>CD tray open/close button (△ OPEN/CLOSE)</b> .....	12
⑱	<b>CD lid</b> .....	12
⑲	<b>Headphone jack (PHONES)</b> .....	19

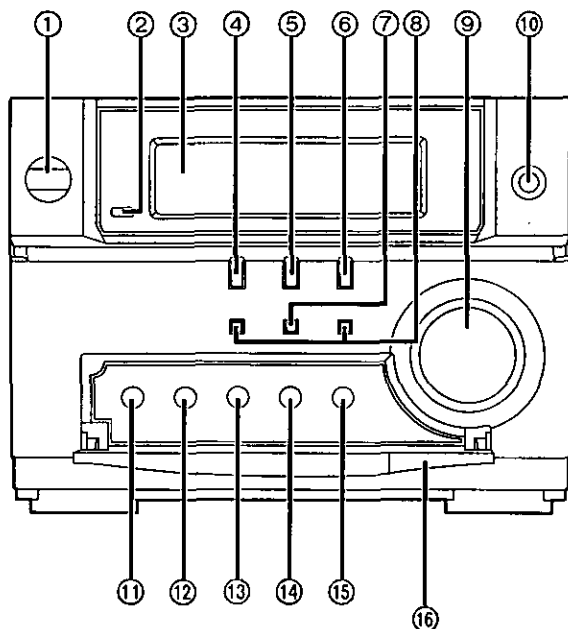

Top view

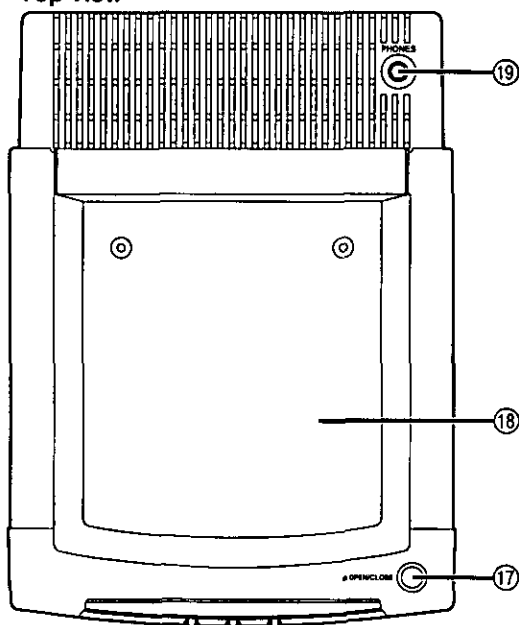

Before use



## Front panel controls

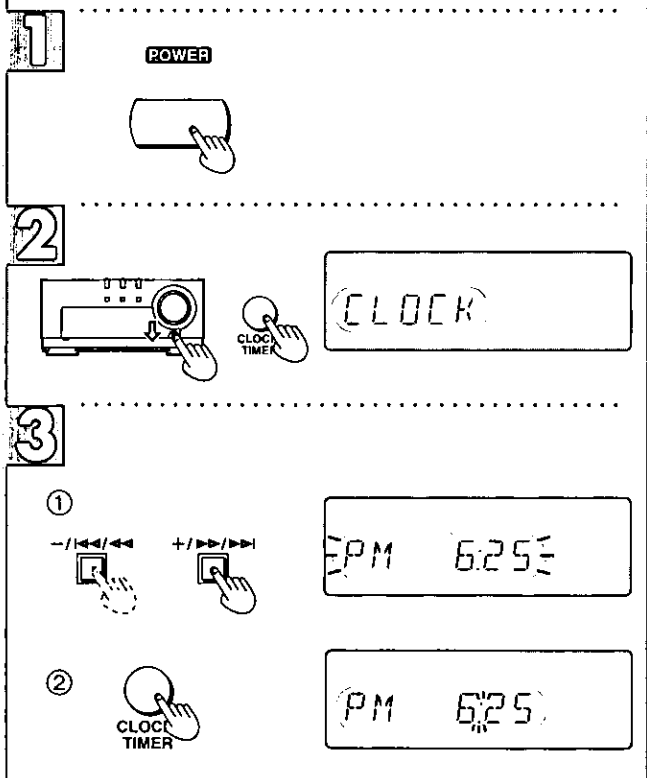
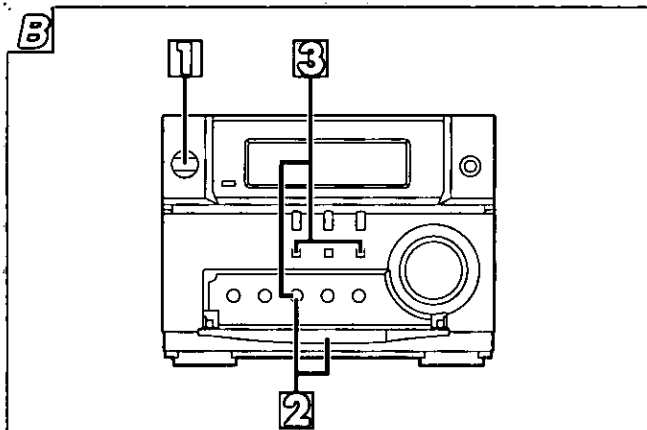
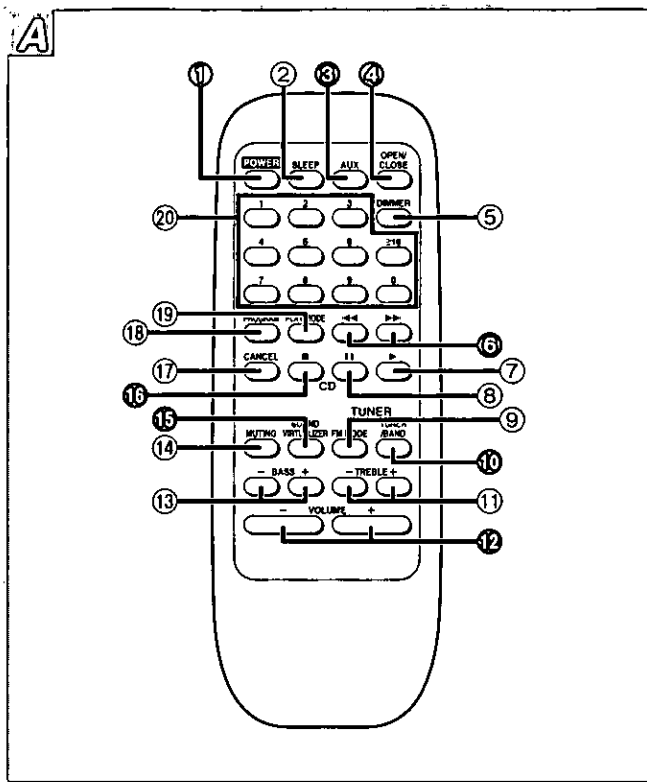

## Remote control

Buttons such as ⑩ function in exactly the same way as the buttons on the main unit.

No.	Name	Ref. page
①	Power button (POWER)	9
②	Sleep button (SLEEP)	18
③	AUX button (AUX)	19
④	CD tray open/close button (OPEN/CLOSE)	12
⑤	Dimmer button (DIMMER)	15
⑥	Skip/search buttons ( <<, >> )	12
⑦	Play button (▷)	12
⑧	Pause button (  )	12
⑨	FM mode button (FM MODE)	11
⑩	Tuner/band button (TUNER/BAND)	10, 11
⑪	Treble buttons (- TREBLE +)	15
⑫	Volume buttons (- VOLUME +)	11, 12
⑬	Bass buttons (- BASS +)	15
⑭	Muting button (MUTING)	15
⑮	Sound virtualizer button (SOUND VIRTUALIZER)	15
⑯	Stop button (□)	12
⑰	Cancel button (CANCEL)	14
⑱	Program button (PROGRAM)	14
⑲	Play mode select button (PLAY MODE)	13
⑳	Numeric buttons	13, 14

## Setting the time



This is a 12-hour display clock.

This example in the figure shows how to set the time for 6:25 p.m..

**1** Switch on the power.

**2** Open the front cover and press **CLOCK/TIMER** to select "CLOCK".

Every time you press the button;

CLOCK →   PLAY

↑  Previous display 

**3** (within 5 seconds or so)

① Press **-/|<</><<** or **+/|>>/>>|** to show the present time.

② Press **CLOCK/TIMER** to finish setting the time.

The display will return to the previous display setting after about 4 seconds.

## To display the time

Press **CLOCK/TIMER** to select "CLOCK".

The time will be displayed for about 5 seconds and then the display will return to whatever was previously displayed.

## For your reference

If the time has been set, the display will default to present time when in standby mode.

## Presetting radio broadcasts

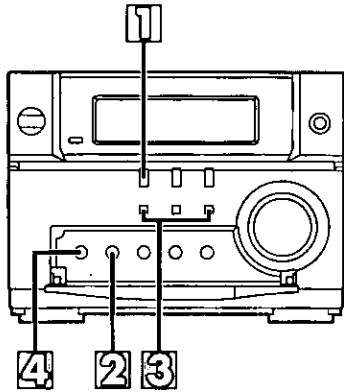

- Up to 12 stations can each be set in the FM and AM bands automatically.
- If broadcast frequencies are preset in the memory, you can easily tune in any of these frequencies from the system or remote control unit.
- You can preset just those stations you like. (See "Presetting only your favourite stations" below.)

Preset each station in the FM and AM bands in the following procedures.

- 1 Press TUNER/BAND to select "FM" or "AM".**  
The power will come on automatically.  
Every time you press the button; "FM" ↔ "AM".
- 2 Press TUNE MODE to select "MANUAL".**  
Every time you press the button; "MANUAL" ↔ "PRESET".
- 3 Press -/◀◀/◀◀ or +/▶▶/▶▶ until the display shows the frequency from which you want to begin automatic memory presetting.**

### Tips on tuning in radio stations

- ① Hold down either button until the frequency starts scrolling. Continue to hold the button.
- ② When nearing the desired frequency, press the button repeatedly until the station is tuned in.

- 4 Press and hold down MEMORY until the frequency begins to change.**  
This will start presetting automatically. When finished, the radio will tune in the last station memorized.

If auto presetting is not possible because radio signals are weak or for some other reason, do the following.

### Presetting only your favourite stations

Preset the stations one at a time.

1. Perform step 1 above. Then, press MEMORY ("MEMO" flashes) and select a station with -/◀◀/◀◀ and +/▶▶/▶▶.
2. While "MEMO" is flashing press MEMORY again and select a preset channel with -/◀◀/◀◀ or +/▶▶/▶▶.
3. Press MEMORY to preset the station.

### Memory retention

Your preset frequencies are retained in memory for about 2 weeks while the system is unplugged.

### FM allocation settings

The FM frequency step is set to 0.2 MHz at the time of shipment. By adjusting the allocation, you can enable the tuner to receive FM broadcasts allocated in 0.1 MHz steps. Press and hold TUNER/BAND. After a few seconds the display will change to a flashing display of the current minimum FM frequency. If you continue to hold the button down, the minimum frequency will change. Release the button at this time.

To return to the original frequency indication, repeat above.

### Note

After changing the "allocation" setting, the frequencies you previously preset in the memory will be cleared.

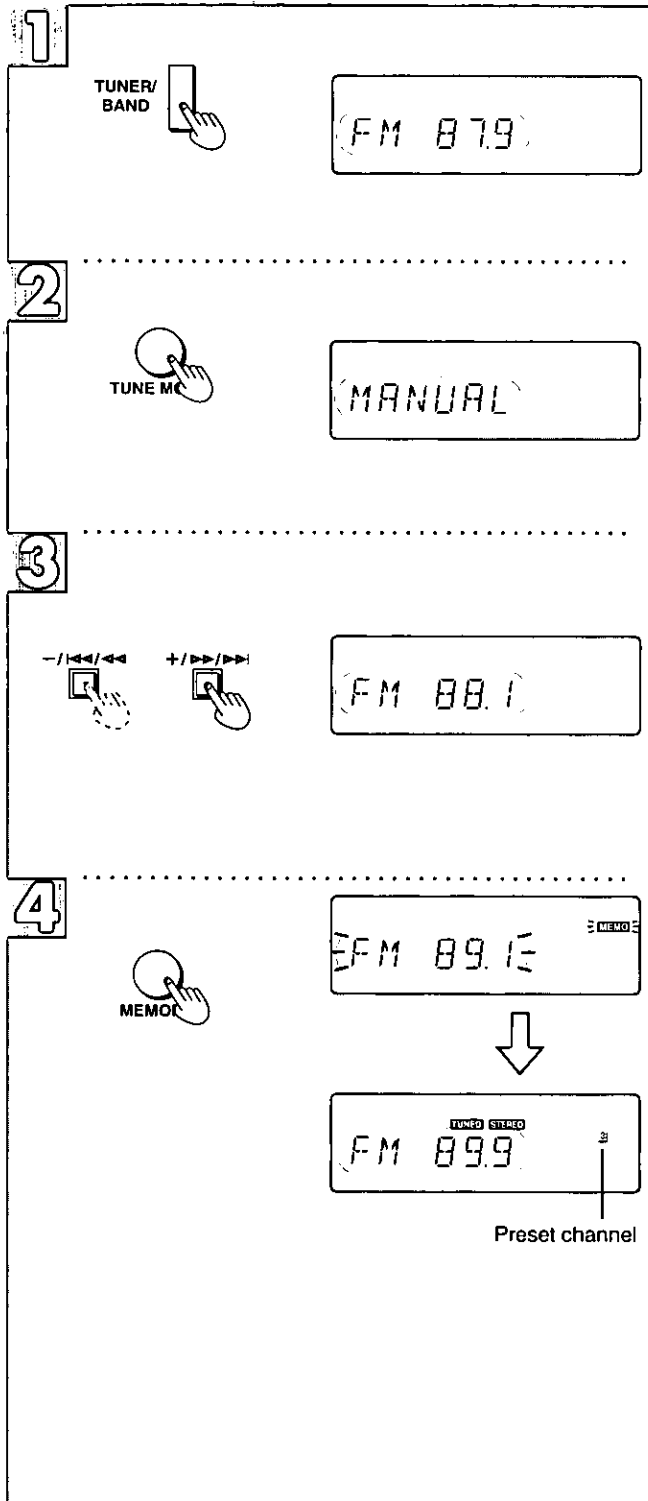

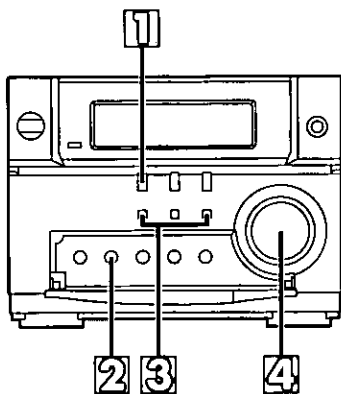

**1 Press TUNER/BAND to select "FM" or "AM".**

The power will come on automatically.  
Every time you press the button; "FM" ↔ "AM".

**2 Press TUNE MODE to select "PRESET" or "MANUAL".**

Every time you press the button; "MANUAL" ↔ "PRESET".

PRESET: For preset stations  
MANUAL: For non-preset stations

**3 Press -/◀◀/◀◀ or +/▶▶/▶▶ to select the desired broadcast.**

"STEREO" lights when an FM stereo broadcast is being received. "TUNED" lights when you precisely tune in a station.

**4 Adjust the volume.**

**One-touch play**

When the system is OFF, the broadcast station last tuned will be received automatically when you press TUNER/BAND.

**Auto tuning**

Auto tuning is an easy way to tune in non-preset stations (select "MANUAL" in step 2).

**Hold down either -/◀◀/◀◀ or +/▶▶/▶▶ and release the button when the frequency starts scrolling.**

The radio frequency will stop automatically on the first station it picks up. When there is outside interference, the radio may stop on a non-broadcast frequency.

Hold down either -/◀◀/◀◀ or +/▶▶/▶▶ to resume auto tuning.

**To stop auto tuning**

Press either -/◀◀/◀◀ or +/▶▶/▶▶ again.

**If noise is excessive in the FM stereo mode**

*(by remote control only)*

**Press FM MODE.** ("MONO" will light up.)

Sound will be produced in monaural, but this also reduces noise. Press the button again to cancel. "MONO" will go out.

**For your reference**

You can preset FM stations in monaural. Make sure "MONO" lights up. Then follow "Presetting only your favourite stations" on page 10 to preset FM stations in monaural.

Normally, you'll want to listen in stereo, so leave "MONO" off. This way, you can listen to stereo broadcasts in stereo, and monaural broadcasts in mono.

**Note**

If you preset stations in memory, you can tune in a preset station by simply selecting the preset channel with the numeric buttons on the remote control.

1. Press TUNER/BAND on the remote control.
2. Press TUNER/BAND to select "FM" or "AM".
3. Press the numeric button(s) to select the desired preset channel.  
To select a two-digit channel  
Press ≥10 and then the two numbers you want within 10 second or so.

## Listening to CDs

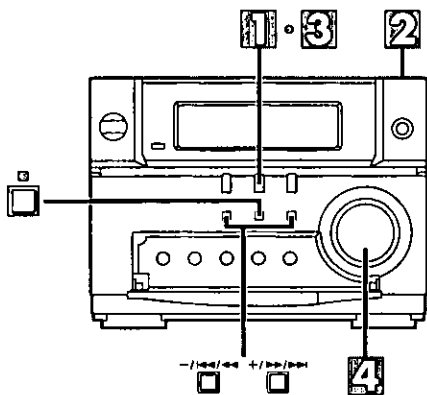

### Normal play

#### 1 Press CD.

The power will come on automatically.

#### 2 Press $\Delta$ OPEN/CLOSE to open the CD lid.

Insert the CD with label facing upward.

Press  $\Delta$  OPEN/CLOSE to close the CD lid.

Total number of tracks and total playing time will appear on the display.

#### Note

Use  $\Delta$  OPEN/CLOSE at all times.

The lid opening mechanism can be damaged if you attempt to open and close the lid by hand.

#### 3 Press $\triangleright/\parallel$ .

Play will start from the first track on the CD.

Play will stop automatically when the last track on the CD finishes playing.

#### 4 Adjust the volume.

### To stop the CD

Press  $\square$ .

To pause	Press $\triangleright/\parallel$ during playback. To resume playback, press $\triangleright/\parallel$ .
To search forward/backward	Hold down $-/\lll/\lll$ (backward) or $+/\ggg/\ggg$ (forward) during playback or pause mode.
To skip forward/backward	Press $-/\lll/\lll$ (backward) or $+/\ggg/\ggg$ (forward) during playback or pause mode.

### When " $\triangleright$ " appears on the display

This indicates there are 13 or more tracks on the CD.

#### Note

- During random play (page 13), you cannot skip to tracks which have already been played.
- During program play (page 14) or random play, you cannot search forward or backward over tracks.
- During program play, skipping is always in the programmed order, whether forward or backward.

### One-touch play

When the system is OFF, playing starts automatically when you press  $\triangleright/\parallel$ .

### For your reference

- The units turns on when  $\Delta$  OPEN/CLOSE is pressed. The lid also opens.
- If you press  $\triangleright/\parallel$  instead of  $\Delta$  OPEN/CLOSE after inserting a CD, the lid will close and play will start directly from track 1.

### To prevent damage $\square$

Do not use irregular shape CDs.

**1**

**2**

**3**

Number of tracks

Total playing time

Label must face upward

**3**

Track number

Elapsed playing time

**4**

VOLUME DOWN

UP

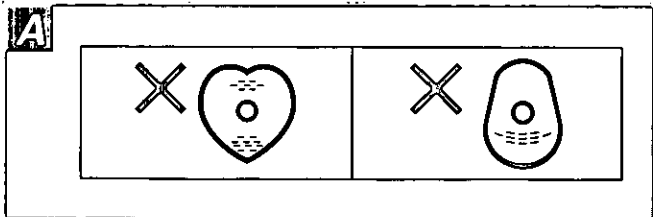

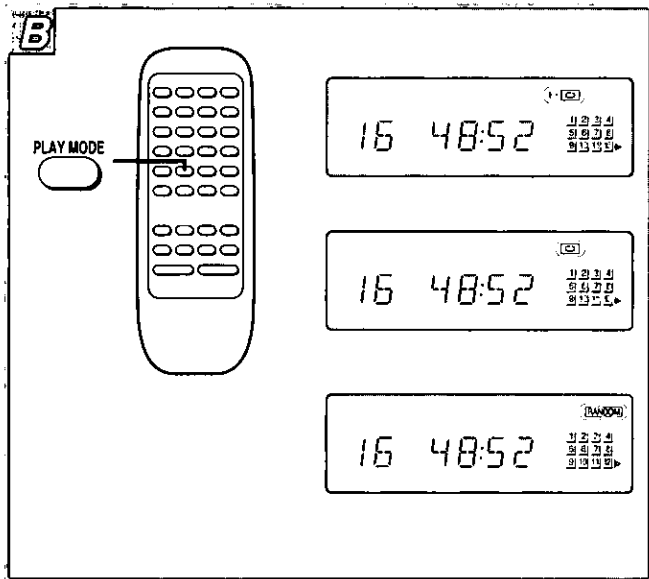
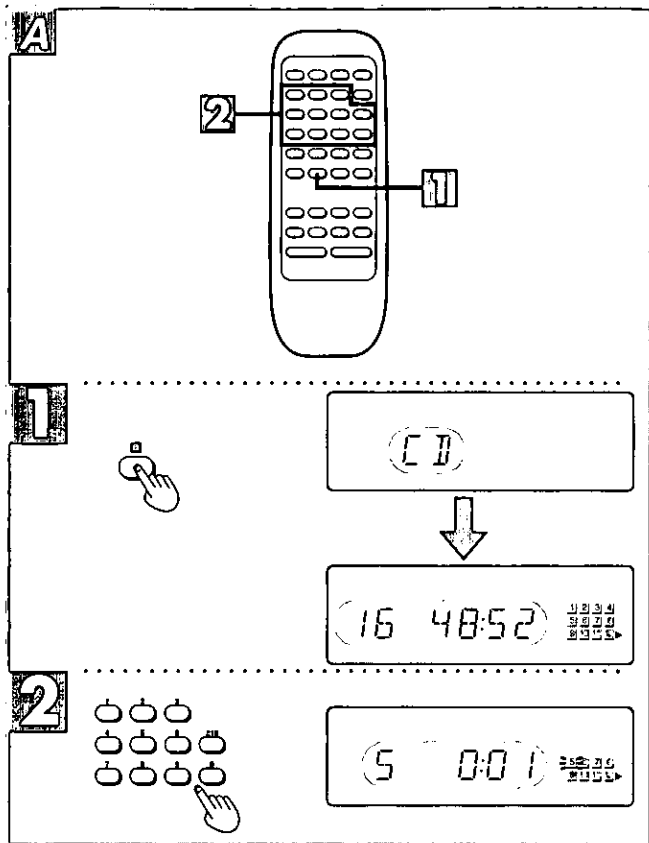

### Direct access play

*(by remote control only)*

Direct access allows you to start normal play from a specific track to the last track on the CD.

- 1 Press to select the CD mode.
- 2 Press the numeric button(s) to select the desired track number.  
Play will start with the track you select.

### To select a two-digit track

Press  $\geq 10$  and then the two numbers you want.

#### For example

Track no. 20:  $\geq 10 \rightarrow 2 \rightarrow 0$

Track no. 35:  $\geq 10 \rightarrow 3 \rightarrow 5$

### Repeat play and random play

*(by remote control only)*

Press **PLAY MODE** before or during play to select the desired play mode.

Every time you press the button;

$\rightarrow 1 - \langle \text{REPEAT} \rangle \rightarrow \langle \text{REPEAT} \rangle \rightarrow \langle \text{RANDOM} \rangle \rightarrow (\text{OFF})$

#### To repeat just one track:

Press **PLAY MODE** to select "1- ".

#### To repeat all tracks:

Press **PLAY MODE** to select " ".

#### To start random play:

Press **PLAY MODE** to select " **RANDOM**".

All tracks on the loaded CD will be played in random order.

Playback will stop automatically when all tracks have been played.

### To cancel repeat play and random play

Press **PLAY MODE** to clear "1- ", " " and " **RANDOM**".

Pressing **OPEN/CLOSE** also cancels repeat play and random play.

### To repeat programmed tracks

1. Program desired tracks (steps 1) to 4) on page 14).
2. Press **PLAY MODE** to display " ".
3. Press  $\blacktriangleright$  to begin play.

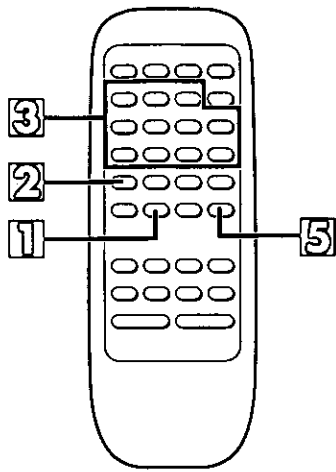

**Program play**

*(by remote control only)*

This function allows you to program up to 24 tracks.

- 1** Press to select the CD mode.
- 2** [In the stop mode] Press PROGRAM.
- 3** Press the numeric button(s) to select the track you want to play in the desired sequence.
- 4** Repeat step **3** until you have programmed all the tracks you want.
- 5** Press . Play will start in the programmed sequence. Play will stop automatically when all the programmed tracks have been played.

**To cancel program play mode**

- Press PROGRAM in the stop mode. Programmed contents will be saved in memory.
- Press in the stop mode. This will also erase the entire program.

**To select a two-digit track**

Press  $\geq 10$  and then the two numbers you want.

**For example**

- Track no. 20:  $\geq 10 \rightarrow 2 \rightarrow 0$
- Track no. 35:  $\geq 10 \rightarrow 3 \rightarrow 5$

**When "FULL" appears**

The number of programmed tracks is limited to 24. No further tracks can be programmed.

**When "----:----" appears**

The total playing time of the programmed tracks has exceeded 99 minutes 59 seconds, or you tried programming track number 25 or more. In either case, you can still program and play the disc.

**Check program contents.**

Check to see if "P" is displayed, then press either or . Everytime you press one of the buttons, the track and program No. are shown on the display.

**Add to the program.**

In stop mode, repeat step **3**.

**Cancel entries.**

From the last programmed track	Press CANCEL.
A specific track only	Check to see if "P" is displayed, then select the track with  or , and press CANCEL within 3 seconds.
All tracks	Press .

**Memory retention**

Your program is retained in memory for about 2 weeks while the system is unplugged.

**To replay your program**

If you turned OFF your program with PROGRAM, you can play it again as explained below.

1. Press PROGRAM.
2. Press .

CD operations

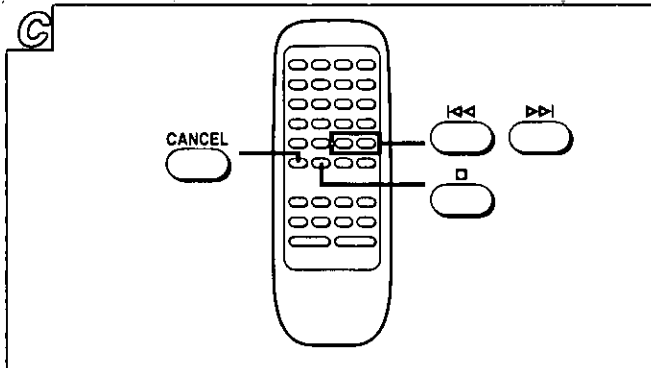
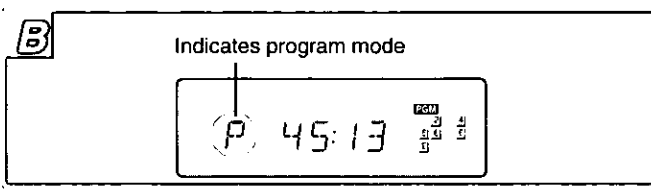
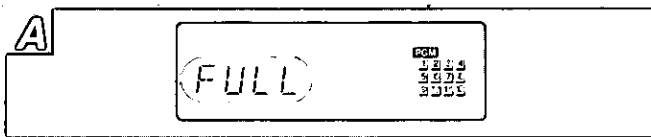
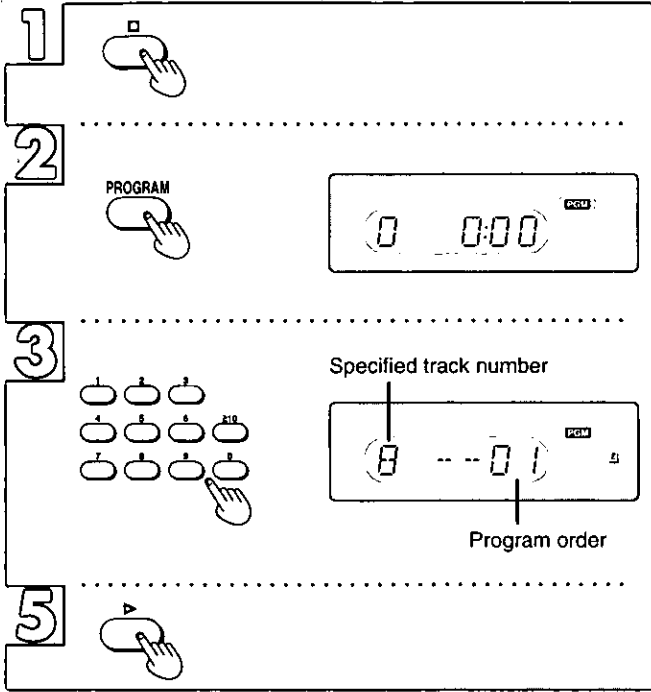

## Changing the sound quality, etc.

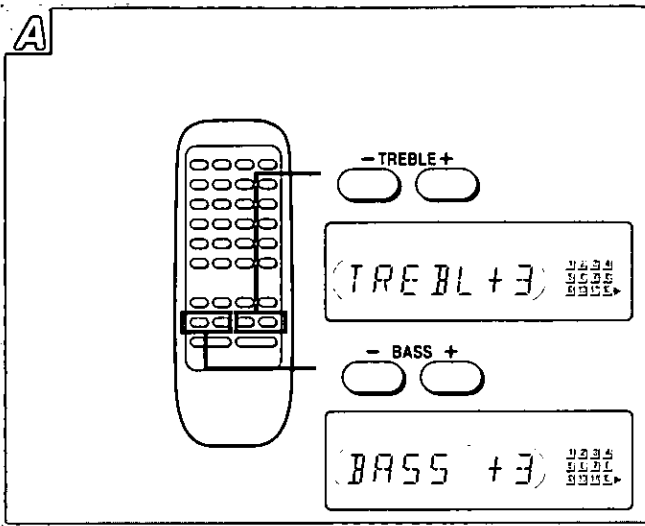

### To adjust the tone quality

*(by remote control only)*

The tone level can be varied within a range of -5 to +5.

**Press BASS (- or +) to adjust the low-frequency sound.**

**Press TREBLE (- or +) to adjust the high-frequency sound.**

### Using the "live" effect (SOUND VIRTUALIZER)

The sound virtualizer leaves middle-range sounds such as vocals clear and gives natural width and depth to music. Sound virtualizer is effective with stereo sound.

**Press SOUND VIRTUALIZER to turn on the effect.**

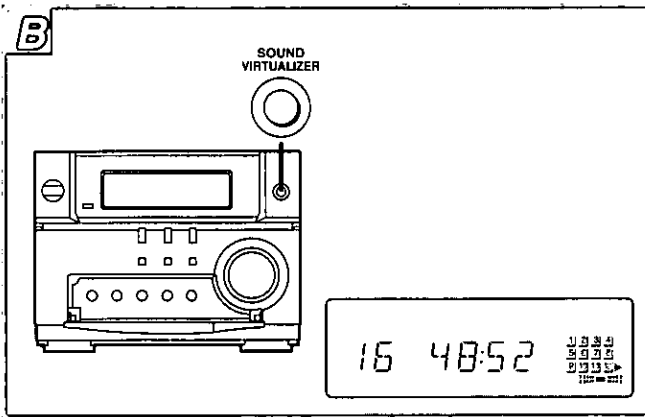

### To cancel

Press SOUND VIRTUALIZER to clear the effect.

- When listening through headphones, the effect is less discernible than through the unit speakers.
- If interference in FM stereo reception increases, cancel the sound virtualizer effect.

### To mute the volume

*(by remote control only)*

This feature is convenient when you have a telephone call, etc.

**Press MUTING.**

Press the button again to cancel. ("MUTING" goes out.)

Muting can also be cancelled by lowering the volume all the way (-- dB).

When the system is turned off, the muting operation will be automatically cancelled.

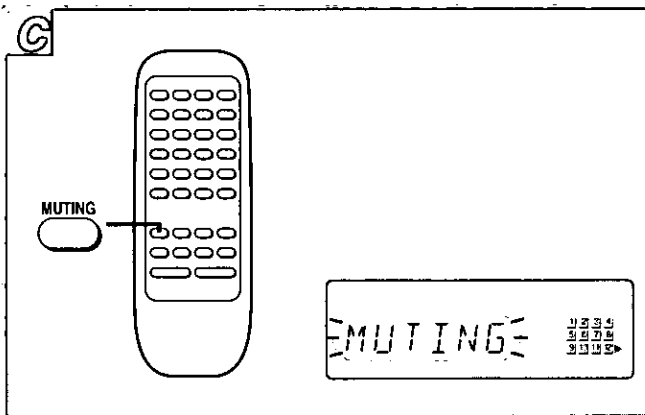

### To dim out the display

*(by remote control only)*

**Press DIMMER.**

The TUNER, CD and AUX button lamps will also go out.

Press once more to return to the original brightness.

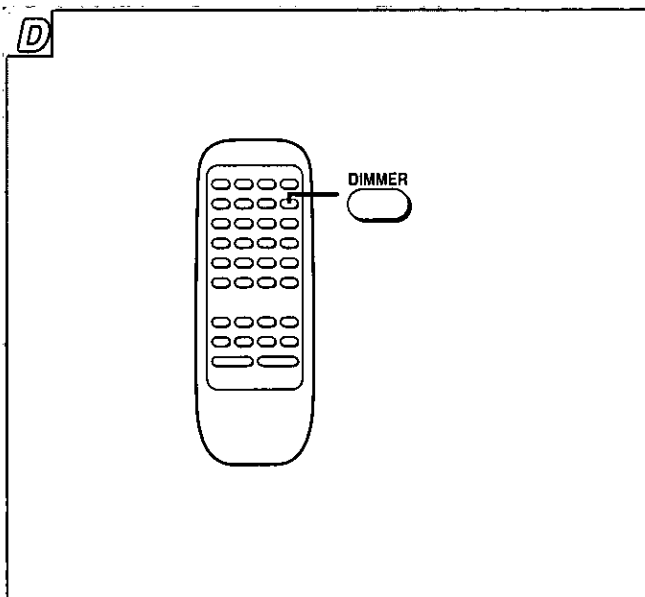

## Using the timer

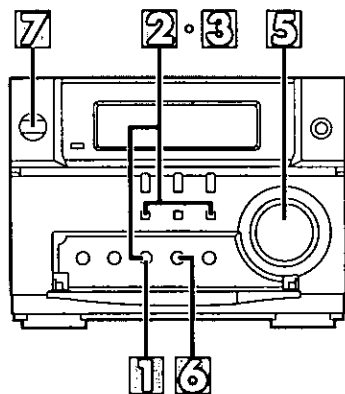

### Using the play timer

Select this timer when you want to use the timer as an alarm clock. You can wake up while listening to music (CD, tuner or aux) at a desired volume level and time.

#### (Preparations)

- Make sure that you have completed "Setting the time" on page 9.
- Switch on the power.

The figure shows how to set the play timer for playing a CD at a volume of -48 dB from 6:30 a.m. to 7:40 a.m.

**1** Press **CLOCK/TIMER** to select "⊖ PLAY".  
Every time you press the button;  
CLOCK → ⊖ PLAY  
← Previous display ←

**2** (Within 8 seconds or so)  
**"ON" time setting**  
① Press **-/|<</<<** or **+/>>/>>** to select the "ON" time.  
② Press **CLOCK/TIMER**.

**3** **"OFF" time setting**  
① Press **-/|<</<<** or **+/>>/>>** to select the "OFF" time.  
② Press **CLOCK/TIMER**.

**4** **Source selection**  
Select the desired source and then prepare for playing.  
To play a CD  
Press **□** and insert CD.  
To play the radio  
Press **TUNER/BAND** and tune in the desired station.  
To play a unit connected to the "AUX" terminals  
Press **AUX**.

**5** **Play volume setting**  
Set the playback volume.

**6** Press **⊖ PLAY** to select "⊖ PLAY".  
Every time you press the button;  
⊖ PLAY ↔ OFF

**7** Press **POWER** to turn off the system.

### 1 Press **CLOCK/TIMER** to select "⊖ PLAY".

Every time you press the button;

CLOCK → ⊖ PLAY  
← Previous display ←

### 2 (Within 8 seconds or so)

#### "ON" time setting

① Press **-/|<</<<** or **+/>>/>>** to select the "ON" time.

② Press **CLOCK/TIMER**.

### 3 "OFF" time setting

① Press **-/|<</<<** or **+/>>/>>** to select the "OFF" time.

② Press **CLOCK/TIMER**.

### 4 Source selection

Select the desired source and then prepare for playing.

To play a CD  
Press **□** and insert CD.

To play the radio  
Press **TUNER/BAND** and tune in the desired station.

To play a unit connected to the "AUX" terminals  
Press **AUX**.

### 5 Play volume setting

Set the playback volume.

### 6 Press **⊖ PLAY** to select "⊖ PLAY".

Every time you press the button;

⊖ PLAY ↔ OFF

### 7 Press **POWER** to turn off the system.



## Using the timer

### Using the play timer

#### To switch the timer OFF

Press  PLAY and check " PLAY" goes out.

#### If you set the timer incorrectly

Repeat the procedure from step .

#### To check settings

Press CLOCK/TIMER to select ".

Two seconds later, the display will change in the following order.

- ① Play start time
- ② Play end time
- ③ Play source
- ④ Playback volume

You can check the settings even when the system is OFF.

#### To enjoy the desired source after the timer setting is completed

Even if you change the volume level or music source, the timer will start with the preset conditions.

1. After step , turn ON the power and start playing the desired source.
2. Press POWER to standby mode after enjoying the source, and confirm a CD has been inserted.

#### Turning the timer ON/OFF

As long as " PLAY" is displayed, the timer will come ON everyday as set.

You can turn the timer ON/OFF by pressing  PLAY while the system is OFF.

Remember that when " PLAY" is displayed, the timer is ON. When not displayed, the timer is OFF.

#### Note

- If the power is on, the timer will not function. The system must be in the standby mode.
- If you switch the power to the standby mode while the play timer is functioning, the OFF time setting will not be activated.
- If AUX is selected as the source, when the timer comes ON, the system will turn ON and will engage "AUX" as the source. If you want to playback from a connected component, set the component's timer to the same time. (See the instruction manual that came with the component.)

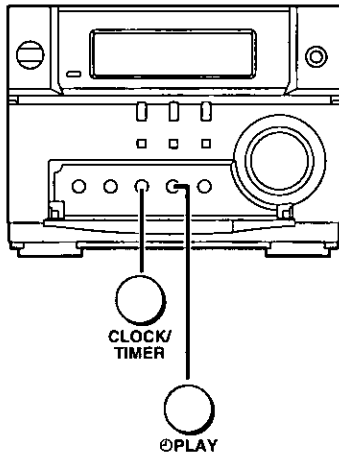

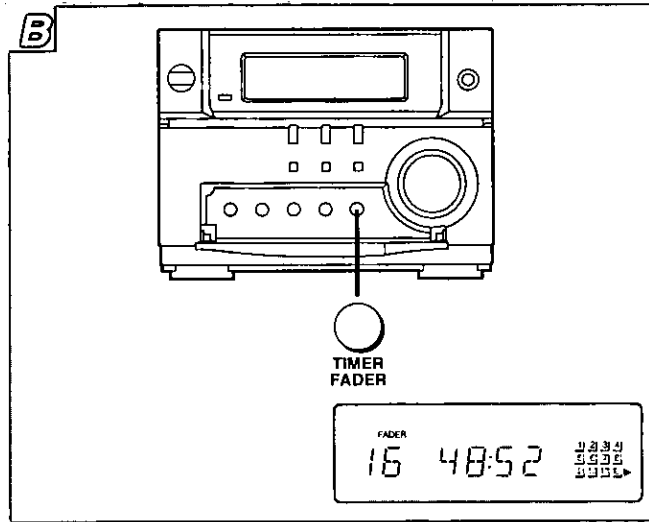
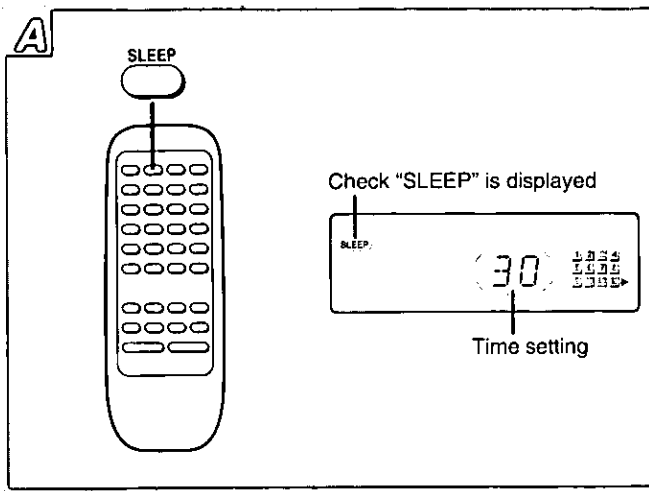

## Using the timer

### Using the sleep timer

This timer turns your system OFF at the set time (Max. 2 hours, settable at 30 minute intervals). It lets you fall asleep listening to music.

**(by remote control only)**

While enjoying the desired source:

**Press SLEEP to select the desired time.**

Every time you press the button;

→ 30 → 60 → 90 → 120 → OFF →

The figure shows how to set the system to standby mode after 30 minutes.

The system is turned off after the set time has elapsed.

### To cancel the sleep timer

Press SLEEP to select "OFF".

### To confirm the remaining time

Press SLEEP.

### To change the time remaining during operation

Press SLEEP to show the remaining time, and then press SLEEP to select the desired time.

### Note

The sleep timer can be used in combination with the play timer. The sleep timer always has priority. Be sure not to overlap timer settings.

## Using the timer fader function (TIMER FADER)

### Using timer fader and sleep timer in combination

Effective in sleep mode with TIMER FADER on. Volume will decrease slowly till the system is turned off at the end of sleep.

Select this function to ease into a comfortable sleep when listening to CD or radio in sleep mode.

### Using timer fader and play timer ON in combination

Effective with timer set and with TIMER FADER on. Volume will increase from 0 to last set volume level gradually.

Select this function to provide a more comfortable wake up when using the sleep timer as an alarm.

**Press TIMER FADER to show "FADER".**

### To cancel the TIMER FADER function:

Press TIMER FADER again to cancel.

"FADER" goes out.

### Notes

Both timer functions are affected while "FADER" is displayed.

Timer fader mode works everyday as long as "FADER" is displayed.

## Using an external unit **A**

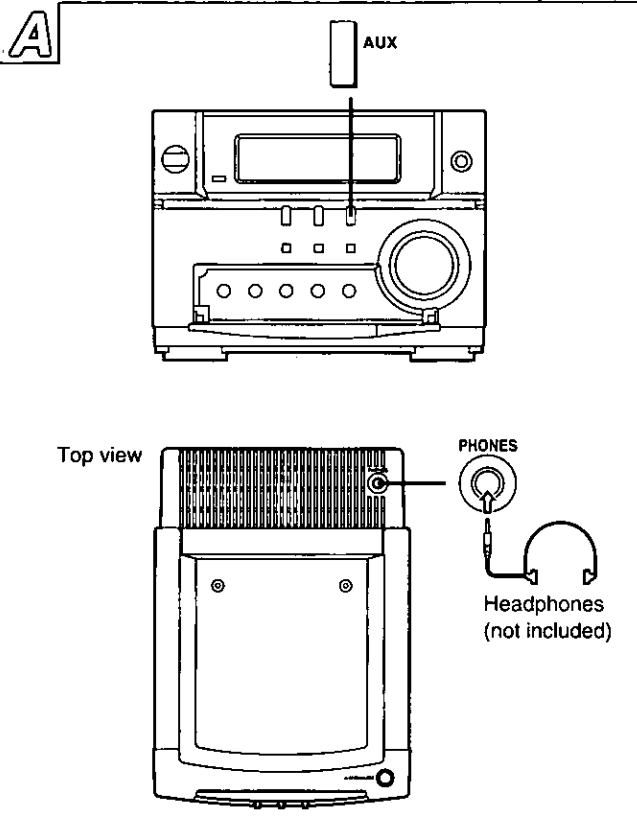

### Listening to an external source

(See page 7 for external unit connection.)

1. Press AUX.
2. Start playback from the external source.  
(Refer to your equipment's operating instructions.)

### Recording from compact discs, etc.

Before recording, prepare the cassette deck for recording (recording level adjustment, etc.).

1. Press to select the source (TUNER/BAND or CD) to be recorded.
2. Start recording on the cassette deck.  
Follow your cassette deck's operating instructions.
3. Start playback from source to be recorded.

### Listening with headphones

Reduce the volume level, and connect the headphones.

Plug type: 3.5 mm (1/8") stereo

#### Note

Avoid listening for prolonged periods of time to prevent hearing damage.

## Concerning CDs

With this system, you can only play CDs having this mark. However, do not use irregular shape CDs. CDs of the sort can damage the unit. **E**



### Handling precautions

Be sure to handle CDs according to the precautions shown on the left (**C**–**E**). Failure to do so may damage the CD or the unit.

- If you are taking the CD from a cold to a warm environment, moisture may form on the CD. Wipe this off with a soft, dry, lint-free cloth before using the CD.
- Do not write on the label side with a ball-point pen or other writing instrument.
- Do not use record cleaning sprays, benzene, thinner, static electricity prevention liquids or any other solvent.
- Do not attach labels or stickers to CDs. (Do not use CDs with exposed adhesive from tape or left over peeled off stickers.)
- Do not use scratch-proof protectors or covers other than those specified for use with this system.

### Storage precautions

Be sure to store CDs in their cases to protect them from dust, scratches, and warping.

Do not place or store CDs in the following places

- Locations exposed to direct sunlight
- Humid or dusty locations
- Locations directly exposed to a heat vent or heating appliance
- In the glove compartment or on the rear deck of an automobile

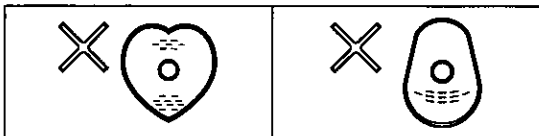
**B****C**

#### How to return CDs to their case

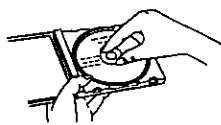

Face label upwards and press down.

**D**

#### How to hold CDs



Do not touch the recorded surface.

**E**

#### How to clean CDs



Wipe from inside outward.

**Other functions****Reference**

# Troubleshooting guide

Before requesting service for this unit, check the chart below for a possible cause of the problem you are experiencing. Some simple checks or a minor adjustment on your part may eliminate the problem and restore proper operation.

If you are in doubt about some of the check points, or if the remedies indicated in the chart do not solve the problem, refer to the directory of Authorized Service Centers (enclosed with this unit) to locate a convenient service center, or consult your dealer for instructions.

**For detailed instructions, contact an authorized servicenter in the U.S.A. and Panasonic Canada Inc. Customer Care Center in Canada. In the U.S.A. 1-800-211-7262 or web site (<http://www.panasonic.com>) In Canada 905-624-5505 or web site ([www.panasonic.ca/faq.html](http://www.panasonic.ca/faq.html))**

Problem	Probable cause(s)	Suggested remedy	Reference page(s)
---------	-------------------	------------------	-------------------

Common problems			
There is no sound when the power is ON.	Volume is set too low.	Adjust the volume level with the volume control.	11, 12
The location of the various musical instruments is not well defined.	The (+) and (-) connections to one of the speakers are reversed.	Connect the speaker cords correctly.	6
The left and right sounds are reversed.	The left and right connections to the speakers are reversed.	Connect the speaker cords correctly.	6
When listening to the external unit, the left and right sounds are reversed.	The left and right connections to the external unit are reversed.	Connect the external unit's cord correctly.	7
Only one speaker is emitting sound.	One of the wires of the speaker cord is disconnected.	Connect the speaker cord correctly.	6
There is no sound when a source is being played.	The (+) and (-) wire of the speaker cords are shorted.	Switch the system to the standby mode, and reconnect the speaker cords so that they are not shorted. Then switch on the power.	6
"ERROR" message appears on the display.	Wrong operation has been done.	Operate the unit correctly by following the operating instructions.	
"---:---:---" appears on the display	<ul style="list-style-type: none"> <li>• You plugged the power cord in for the first time.</li> <li>• There was a power failure recently.</li> </ul>	Set the time.	9

While listening to FM broadcasts			
There is a "rushing noise" during a stereo broadcast which is not audible during a monaural broadcast.	The transmitting station is a long distance away.	If you are using an indoor antenna, change to an outdoor antenna.	7
You hear excessive noise during a stereo broadcast, and occasionally the sound disappears.	The installation location and orientation of the antenna are unsuitable.		
The stereo indicator ("STEREO") flickers and does not light completely.	The transmitting station is a long distance away. The power of the TV set or VCR is ON.		
The sound during a stereo broadcast is highly distorted.	There is a building or mountain nearby. [Distortion is caused by interference between the signal from the transmitting station (direct wave) and the signal reflected from the building or mountain (reflected wave).]	Use a high-grade outdoor antenna, and install it in a good location, height, and orientation for reception.	7

While listening to AM broadcasts			
You hear an unusual beat sound.	You are using the system at the same time you are playing a TV set.	Switch off the TV set, or use the system further away from it.	
You hear a low-frequency hum.	The antenna wire is near the power cord.	Separate the antenna wire from the power cord.	
You hear excessive noise.	The AM loop antenna is too near the system.	Move the antenna further away from the system.	

Problem	Probable cause(s)	Suggested remedy	Reference page(s)
---------	-------------------	------------------	-------------------

When there is a television set nearby			
The picture on the TV disappears or stripes appear on the screen.	The location and orientation of the antenna are incorrect.	If you are using an indoor antenna, change to an outdoor antenna.	7
	The wiring at the back of the system is unsuitable.	Separate the antenna wire of the TV set from the system.	

While listening to CDs			
The display does not show the correct indication. CD play does not start when you press the play button.	The CD label is upside down.	Set the CD with the label facing upward.	12
	The CD is dirty.	Wipe the CD with a soft cloth.	19
	The CD is scratched.	Replace the CD with a new one.	
	The CD is badly warped.		
	The CD is nonstandard.	Replace the CD with a different one.	19
There is condensation inside the CD player because of a sudden change in temperature.	Wait for 60 minutes before using the CD player.		
A certain music passage can't be played correctly.	The CD is dirty.	Wipe the CD with a soft cloth.	19

While using the remote control			
The system cannot be operated with the remote control.	The batteries are installed in the reverse polarity.	Re-insert the batteries in the correct polarity.	5
	The batteries are run-down.	Replace the batteries with new batteries.	5

## Maintenance

### If the surfaces are dirty

To clean this unit, wipe with a soft, dry cloth.  
If the surfaces are extremely dirty, use a soft cloth dipped in a soap-and-water solution or a weak detergent solution.

- Never use alcohol, paint thinner or benzine to clean this unit.
- Before using chemically impregnated cloth, read the instructions that came with the cloth carefully.

### Lens care

Open the CD lid and clean the lens with a blower (not included).  
If the lens is extremely dirty, clean it with a cotton swab.  
Recommended product: Lens cleaner kit (SZZP1038C)

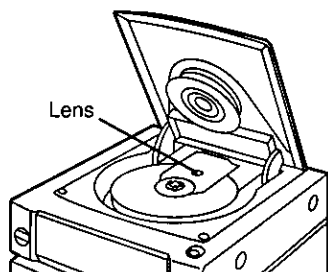

# Technical specifications

## AMPLIFIER SECTION

Input sensitivity	
AUX	250 mV
Input/output impedance	
AUX	47 k $\Omega$
Headphone	16–32 $\Omega$

## FM TUNER SECTION

Frequency range	87.9–107.9 MHz (200 kHz steps)
	87.5–108.0 MHz (100 kHz steps)
Sensitivity	16.3 dBf (1.8 $\mu$ V, IHF'58)
Antenna terminal(s)	75 $\Omega$ (unbalanced)

## AM TUNER SECTION

Frequency range	520–1710 kHz (10 kHz steps)
Sensitivity	
S/N 20 dB	500 $\mu$ V/m

## CD SECTION

Sampling frequency	44.1 kHz
Decoding	16 bit linear
Beam source/wave length	Semiconductor laser/780 nm
Number of channels	2 channels stereo
Wow and flutter	Below measurable limit
Digital filter	8 fs
D/A converter	MASH (1 bit DAC)

## SPEAKER SECTION

Type	2 way speaker system
Speaker(s)	
Full range	10 cm cone type
Tweeter	6 cm cone type
Impedance	6 $\Omega$
Input power	30 W (Music), 15 W (DIN)
Output sound pressure level	84 dB/W (1.0 m)
Cross over frequency	6 kHz
Frequency range	48 Hz–20 kHz (–16 dB)
	60 Hz–18 kHz (–10 dB)
Dimensions (W×H×D)	140×223×228 mm (5 <sup>1</sup> / <sub>2</sub> "×8 <sup>25</sup> / <sub>32</sub> "×8 <sup>3</sup> / <sub>32</sub> "
Weight	1.9 kg (4.2 lb.)

## GENERAL

Power supply	AC 120 V, 60 Hz
Power consumption	45 W
Dimensions (W×H×D)	190×149×303 mm (7 <sup>15</sup> / <sub>32</sub> "×5 <sup>7</sup> / <sub>8</sub> "×11 <sup>15</sup> / <sub>16</sub> "
Weight	3.6 kg (7.9 lb.)

### Note:

Specifications are subject to change without notice.  
Weight and dimensions are approximate.

MASH is a trademark of NTT.

## **Product service**

Do not attempt to remove the cover(s) or repair the unit yourself. Refer servicing to qualified personnel only. The servicer will require all components to service your system. Therefore, should service ever be necessary, be sure to bring the entire system.

## **Product information**

For product service, product information or assistance with product operation, refer to the servicer directory.

---

**Panasonic Consumer Electronics  
Company, Division of Matsushita  
Electric Corporation of America**  
One Panasonic Way Secaucus,  
New Jersey 07094  
<http://www.panasonic.com>

**Panasonic Sales Company,  
Division of Matsushita Electric of  
Puerto Rico, Inc. ("PSC")**  
Ave. 65 de Infantería, Km. 9.5  
San Gabriel Industrial Park, Carolina,  
Puerto Rico 00985

**Panasonic Canada Inc.** (En)  
5770 Ambler Drive,  
Mississauga, Ontario  
L4W 2T3  
[www.panasonic.ca](http://www.panasonic.ca)



# Technics®

## Passive Subwoofer System Enceinte acoustique passive d'extrêmes graves

# SB-W500

### Operating Instructions Manuel d'utilisation

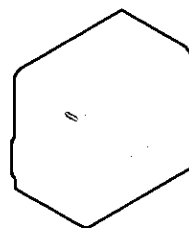
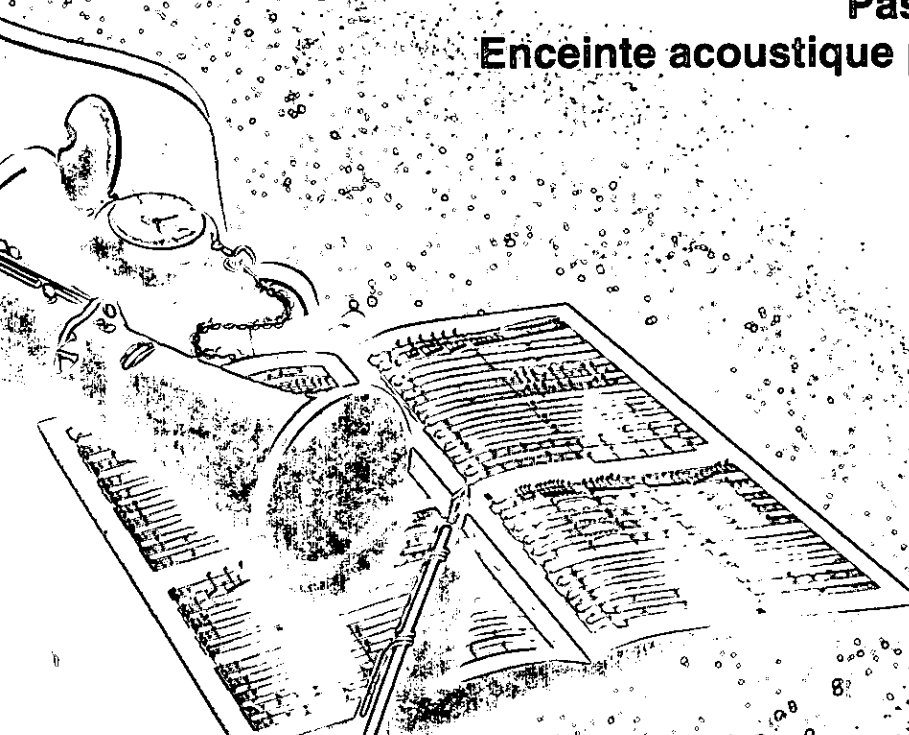

Before operating this unit, please read these instructions completely. Please save this manual.

Il est recommandé de lire attentivement le présent manuel avant d'utiliser l'appareil. Conserver ce manuel.

### Dear Customer

Thank you for purchasing this product.

#### User memo:

DATE OF PURCHASE _____
DEALER NAME _____
DEALER ADDRESS _____
_____
TELEPHONE NUMBER _____

The model number and serial number of this product can be found on either the back or the bottom of the unit. Please note them in the space provided below and keep for future reference.

MODEL NUMBER SB-W500  
SERIAL NUMBER \_\_\_\_\_

### Cher client

Nous vous remercions d'avoir arrêté votre choix sur cet appareil Technics.

#### Homologation:

DATE D'ACHAT _____
DÉTAILLANT _____
ADRESSE DU DÉTAILLANT _____
_____
N° DE TÉLÉPHONE _____

Il est recommandé de noter, dans l'espace prévu ci-dessous, le numéro de modèle et le numéro de série inscrits à l'arrière, ou sous le fond de l'appareil, et de conserver ce manuel pour référence ultérieure.

NUMÉRO DE MODÈLE SB-W500  
NUMÉRO DE SÉRIE \_\_\_\_\_

### Supplied accessories Accessoires fournis

Speaker feet (4 pcs.)  
Pieds de l'enceinte (4)

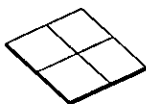

(RFA0631A-K)

Use numbers indicated in parentheses when asking for replacement parts.

(Only for U.S.A.)

To order accessories contact 1-800-332-5368 or web site (<http://www.panasonic.com>).

Lors de la commande de pièces de rechange, utiliser les numéros indiqués entre parenthèses.

## Note

1. Be sure to reduce the volume on the receiver (or amplifier) when the signal input exceeds the rated allowable input to avoid damage to circuitry or other malfunctions.
2. Avoid placing in areas as follows:
  - In direct sunlight
  - Near heating appliances or other sources of heat
  - Where there is high humidity
3. Never use alcohol, paint thinner, benzine or similar chemicals to clean the unit, as they may damage the finish.

## Protection circuitry

This unit incorporates speaker protection circuitry to protect the speaker from damage caused by excessive input or abnormal signals; when excess input is detected, input is automatically interrupted.

### If sound is interrupted...

1. Reduce the volume of the receiver (or amplifier).
2. Check the sound source and connections for any problems.  
If there is no problem, the protection circuitry will reset in a few minutes.

### After the protection circuit is reset...

Take care not to increase the receiver's volume too high.

## Technical specifications

Type	1 way, 2 speaker system Bass-reflex
Speaker	
Woofer	14 cm (5-1/2") cone type X2
Impedance	8 Ω/stereo, 16 Ω/mono
Input power	160 W/stereo, 320 W/mono (Music) 80 W/stereo, 160 W/mono (DIN)
Output sound pressure	83 dB/W (1.0 m)
Frequency range	40 Hz-550 Hz (at -16 dB) 37 Hz-530 Hz (at -10 dB)
Dimensions (W×H×D)	318.6×370×412.3 mm (12-17/32"×14-9/16"×16-7/32")
Weight	9.0 kg (19.84 lb.)

**Note:** Specifications are subject to change without notice.  
Weight and dimensions are approximate.

### Product service

Do not attempt to remove the cover(s) or repair the unit yourself.  
Refer servicing to qualified personnel only.

### Product information

For product service, product information or assistance in product operation, refer to the servicenter directory.  
For detailed instructions, contact an authorized servicenter in the U.S.A. and Panasonic Canada Inc. Customer Care Center in Canada.

In the U.S.A. 1-800-332-5368 or web site  
(<http://www.panasonic.com>)  
In Canada 905-624-5505 or web site  
([www.panasonic.ca/faq.html](http://www.panasonic.ca/faq.html))

## Nota

1. Afin de prévenir tout risque de dommage aux circuits ou tout problème de fonctionnement, baisser le volume sur le récepteur (ou l'amplificateur) dans le cas où le signal d'entrée excède la puissance admissible nominale.
2. Éviter de:
  - exposer l'enceinte aux rayons solaires directs;
  - placer l'enceinte à proximité d'une source de chaleur;
  - placer l'enceinte dans un endroit humide.
3. Ne jamais utiliser de solvant pour nettoyer le coffret de l'enceinte. Cela pourrait endommager le fini.

## Circuit de protection

Cet appareil est muni d'un circuit de protection contre tout dommage imputable à des signaux trop intenses ou anormaux. Si de tels signaux sont détectés, l'entrée est automatiquement interrompue.

### Dans le cas où le son est coupé...

1. Baisser le volume sur le récepteur (ou l'amplificateur).
2. Vérifier la source sonore et les raccordements.  
Si tout semble normal, le circuit de protection sera réarmé après quelques minutes.

### Suite au réarmement du circuit de protection

Prendre garde à ne pas trop monter le volume sur le récepteur.

## Données techniques

Type	Enceinte 1 voie à 2 haut-parleurs avec évent réflex
Haut-parleur	
Graves	Type à cône de 14 cm (5-1/2 po) X2
Impédance	8 Ω/stéréo, 16 Ω/mono
Puissance d'entrée	160 W/stéréo, 320 W/mono (Musique) 80 W/stéréo, 160 W/mono (DIN)
Niveau de pression sonore de sortie	83 dB/W (1,0 m)
Gamme de fréquence	40 Hz-550 Hz (à -16 dB) 37 Hz-530 Hz (à -10 dB)
Dimensions (L×H×P)	318,6×370×412,3 mm (12-17/32 po×14-9/16 po×16-7/32 po)
Poids	9,0 kg (19,84 lb)

**Nota:** Sujet à changements sans préavis.  
Le poids et les dimensions sont approximatifs.

### Service après-vente

Advenant que l'appareil nécessite une révision quelconque, consulter la liste incluse des centres de service agréés ou voir le détaillant auprès de qui l'appareil a été acheté.

### Informations techniques

Pour tout renseignement ou service, consulter la liste des centres de service agréés ci-jointe.

Pour de plus amples détails, contacter le Service à la clientèle de Panasonic Canada Inc. au (905) 624-5505 ou notre site web à [www.panasonic.ca/faq.html](http://www.panasonic.ca/faq.html)

Panasonic Consumer Electronics Company, Division of Matsushita Electric Corporation of America  
One Panasonic Way Secaucus, New Jersey 07094  
<http://www.panasonic.com>

Panasonic Sales Company, Division of Matsushita Electric of Puerto Rico, Inc. ("PSC")  
Ave. 65 de Infantería, Km. 9.5 San Gabriel Industrial Park, Carolina, P.R. 00985

Panasonic Canada Inc.  
5770 Amber Drive, Mississauga, Ontario L4W 2T3  
[www.panasonic.ca](http://www.panasonic.ca)



RQT4520-1P

H1297G0

